

The CelAccess GC1010 is a cellular monitoring device as well as an access control device all in a simple to install unit. It runs off 12vDC (transformer provided) and has one input for monitoring a dry contact relay such as intrusion system, motion sensor, door position switch, etc. The relay on the GC1010 can control electronic locks, gates and doors using any phone or Internet connection. The power consumption is extremely low making it ideally suited for solar powered applications.

The wireless unit is not weather proof and must be installed inside a weatherproof enclosure. (The GC1010P is also available which includes a NEMA 3 enclosure.)

Parts included

- GC1010 modem
- Mounting rail
- Power/data cable with in-line relay (N/O or N/C wiring options) and resettable fuse
- Magnetic mount antenna
- 110vAC to 12vDC transformer

Tools Needed For Basic Installation

- Wire nuts or appropriate terminals/connectors
- Wire strippers
- Wire cutters
- Digital or Analog multi-meter

Specifications

- Operating temperature: -22 to 167 Fahrenheit
- Input for monitoring (e.g. intrusion detection, magnetic switch, etc.)
- N/O or N/C relay (contact rating 1A @ 30VDC)
- Cellular – quad-band GSM
- Power
 - 12vDC input (transformer provided)
 - Resettable fuse
 - Current draw
 - Standby: 17mA
 - Transmit 100mA (short pulse)
 - Hold open: 30mA
- Dimensions: 3.5" X2.1" X1"

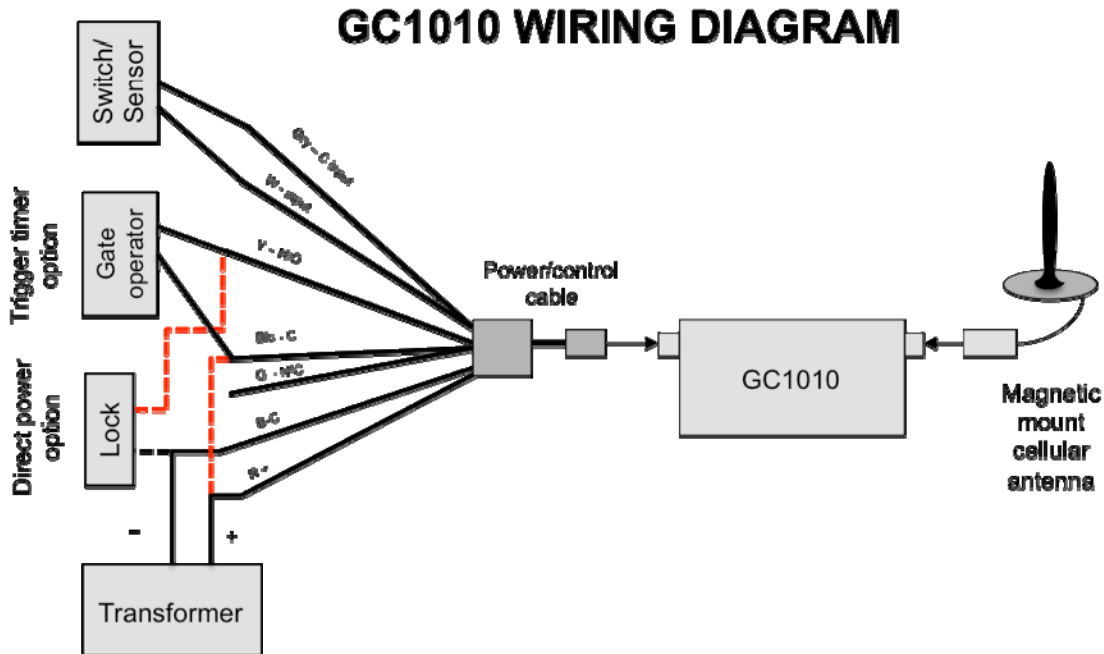

Step 1 – Connect antenna: The GC 1010 wireless device is supplied with a magnetic mount antenna. Thread the antenna out of the control panel enclosure and attach the magnet as high as possible to provide the best signal possible. Attach the antenna to the GC1010 making sure that all connections are tight including the adapter.

Step 2 – Connect power and control cable: The power/control cable has a black, 4 pin connector that is attached to the GC1010 and seven wires including: 2 power, 3 relay (C,NO, NC) and 2 input wires for monitoring a dry contact. **NOTE: Connect the bare wires first before attaching the black connector to the GC1010 device.**

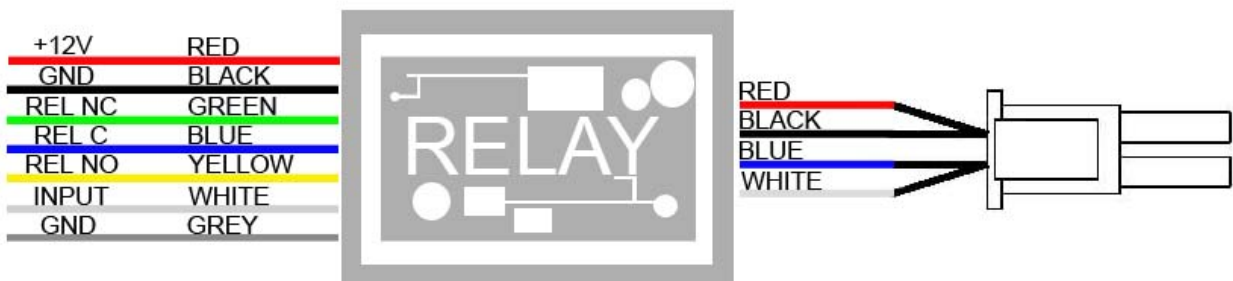

RELAY WIRING

Momentary open - trigger timer: The GC1010 can be connected to a device with a timer such as a gate operator, overhead door or strike lock powered by a timer. Typically, the normally open relay is used for this application. When an open command is sent, the relay will trigger (default is 0.5 seconds).

Momentary open - direct power: Power can be run through the relay on the GC1010P (1A@30vDC max) so the timer of the relay can be used to hold a lock open. Typical examples are strike locks where the lock is held open for 10 seconds when activated. To power the locking device through the relay connect the negative power wire on the lock to the negative wire on the power supply. Run the positive leg of the lock power through the relay by connecting the blue relay wire to the positive wire on the power supply and the other side of the relay (either normally open or normally closed) to the positive wire on the lock. This is illustrated above. **NOTE: When using fail safe locks, use the N/C relay. When using fail secure locks, use N/O relay.**

NOTE: To change the default time of the relay, an account must first be set up. Log in to the account, click on the device tab, select the device and change the relay time. The new relay timer duration will be sent to the GC1010. This may take up to an hour.

Hold open feature: Special open commands can be sent to the GC1010 that hold the relay for the specified period. For example, a hold open command can be sent at 8:00am for 9 hours. The device will then close at 5:00pm. **NOTE: Be sure the device connected to the GC1010 is configured to support continual contact closure. Jumper settings must be changed in many gate operators to support this function.**

INPUT WIRING

The GC 1010 supports the monitoring of any sensor that closes a contact when triggered. Examples include magnetic position switches, photoelectric sensors, intrusion detections systems, etc. Simply connect the contact wires from the sensor to the white and gray wires as shown. **NOTE:** There is an additional fee for use of the sensor monitoring. To select the notification method when the input is triggered, log onto the web site, select the device and modify the settings.

POWER

With the transformer unplugged, connect the positive wire from the transformer to the red wire on the GC1010 and the negative wire from the transformer to the black wire on the GC1010. If 12vDC power is available from the control panel or gate operator, the GC1010 can be wired directly avoiding the need for the transformer. **NOTE: Be sure to connect the polarity correctly.** When the GC1010 is powered on, a red LED will light as described below.

Step 3- Test unit functionality: When the GC1010 is connected to power a red LED next to the antenna connector will blink once, then be on solid. After about fifteen seconds it will register on the cellular network and the LED will blink slowly.

Once this happens, **wait another 30 seconds** then you can use the CelAccess phone system to open the gate/lock. Call 866-ZAP-OPEN (866-927-6736), enter the device number which can be found on the box label or device label, then enter the pound sign. Next, enter the temporary access code found on the box label. If the codes are entered correctly, you will get a verbal confirmation and an “open” command will be sent to the device. It should take less than 30 seconds for the device to receive the command.

NOTE: THE TEMPORARY ACCESS CODE WILL WORK FOR 10 TIMES INCLUDING INSTALLATION TESTING AND OWNER USE. In order to create permanent access codes, the owner must create an account as described in the Quick Start Guide.

Trouble Shooting:

LED does not turn on – If the LED does not turn on, power is not connected to the device. Be sure the leads are connected to the power supply correctly (including the correct polarity) and the connector is firmly attached to the device. Also, be sure that power is 12v DC.

LED stays solid and does not blink – The wireless unit operates on a GPRS cellular network. First, make sure the device is in coverage by checking our web site at www.celaccess.com. If you are in coverage, check the connection of the antenna. If all this is correct, the specific location might be in a poor coverage area. Contact your distributor or CelAccess at 972-231-1999 for a signal booster.

The phone system says that the code is invalid – Be sure you are entering the correct device number followed by the pound key and temporary access code then the pound key. If these are consistently rejected, it is possible the device has not been provisioned, or the temporary access code has expired. Call CelAccess customer service.

The phone system accepts the code but the gate does not open – If the system accepts the device number and access code, then the combination is valid in the CelAccess system. Note: It typically takes about a minute from the time power is connected to the device to when the device is ready to receive a command. Check to make sure the relay wires are connected properly control panel or lock. Use a multimeter to check continuity of the relay wires when an open command is sent. The N/O relay should close for about one half second.

IF THESE DO NOT WORK, CALL CELACCESS CUSTOMER SUPPORT.

Customer Service: 972-231-1999

E-Mail: support@celaccess.com

Customer service is available free of charge. Hours are 9:00 a.m. to 5:00 p.m. CST. If you call, please have your Model and Device ID Number to help our Technicians assist you.