

The CelAccess GC1010P is a cellular monitoring device as well as an access control device all in a simple to install unit. The cellular modem, transformer/power supply (110vAC to 12vDC) and wiring are mounted in a NEMA 3 enclosure with a dome style, cellular antenna mounted on the top. It is suitable for interior and exterior installations. The GC1010P has one input for monitoring a dry contact relay such as intrusion system, motion sensor, door position switch, etc. The relay on the GC1010P can control electronic locks, gates and doors using any phone or Internet connection. The power supply has a low heat, rapid charge circuit for lead acid batteries for backup power (battery not included)

Parts included

- NEMA 3 enclosure
- GC1010 modem
- Power supply with resettable fuse and low heat, rapid battery charger
- Power/data cable with in-line relay (N/O or N/C wiring options) and resettable fuse
- Dome style omni-directional cellular antenna

Tools Needed For Basic Installation

- Wire nuts or appropriate terminals/connectors
- Wire strippers
- Wire cutters
- Screws/nuts for mounting enclosure
- Digital or Analog multi-meter

Specifications

- Operating temperature: -22 to 167 Fahrenheit
- Input for monitoring (e.g. intrusion detection, magnetic switch, etc.)
- N/O or N/C relay (contact rating 1A @ 30VDC)
- Cellular – quad-band GSM
- Power supply – 2A 12vDC output
- Dimensions: 12" x 3" x 13.5"

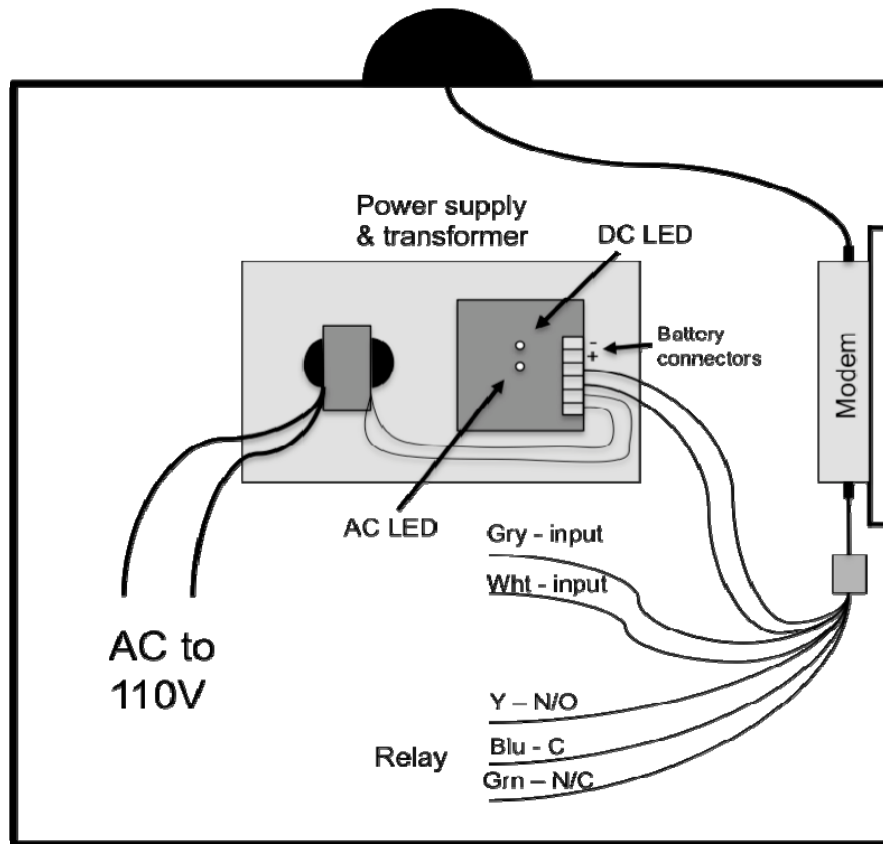

Step 1 – Connect control cable: The control cable has a black, 4 pin connector that is attached to the cellular modem and seven wires including: 2 power (connected to the power supply), 3 relay (C,N/O, N/C) and 2 input wires for monitoring a dry contact.

RELAY WIRING

Momentary open – timer trigger: The GC1010P can be connected to a device with a timer such as a gate operator, overhead door or strike lock. Typically, the normally open relay is used for this application. When an open command is sent, the relay will trigger (default is 0.5 seconds).

Momentary open - direct power: Power can be run through the relay on the GC1010P (1A@30vDC max) so the timer of the relay can be used to hold a lock open. Typical examples are strike locks where the lock is held open for 10 seconds when activated. To power the locking device through the relay connect the negative power wire on the lock to the negative power connector on the power supply. Run the positive leg of the lock power through the relay by connecting the blue relay wire to the positive power connector on the power supply and the other side of the relay (either normally open or normally closed) to the positive wire on the lock. This is illustrated below:

POWER LOCK THROUGH RELAY

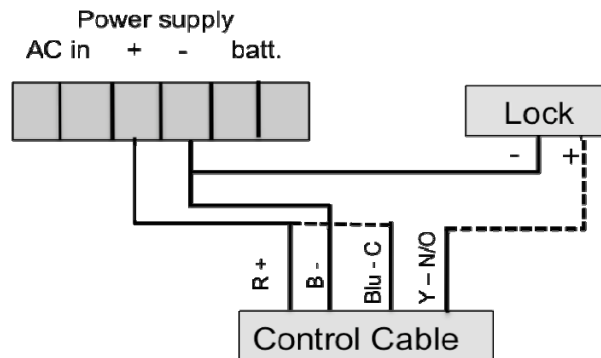

NOTE: When using fail safe locks, use the N/C relay. When using fail secure locks, use N/O relay.

NOTE: To change the default time of the relay, an account must first be set up. Log in to the account, click on the device tab, select the device and change the relay time. The new relay timer duration will be sent to the GC1010. This may take up to an hour

Hold open feature: Special open commands can be sent to the GC1010 that hold the relay for the specified period. For example, a hold open command can be sent at 8:00am for 9 hours. The device will then close at 5:00pm. **NOTE: Be sure the device connected to the GC1010 is configured to support continual contact closure. Jumper settings must be changed in many gate operators to support this function.**

INPUT WIRING

The GC 1010 supports the monitoring of any sensor that closes a contact when triggered. Examples include magnetic position switches, photoelectric sensors, intrusion detections systems, etc. Simply connect the contact wires from the sensor to the white and gray wires. **NOTE:** There is an additional fee for use of the sensor monitoring. To select the notification method when the input is triggered, log onto the web site, select the device and modify the settings.

Step 2 – Connect power: With the AC power turned off, connect the AC wires from the transformer to 110vAC power. Once the AC power wires are connected, turn the AC power on. The AC LED on the power supply should be lit indicating that it has AC power. (Power out of the transformer to the power supply is 24VAC.) The DC LED on the power supply should also be lit indicating that the power supply is providing DC power. An LED on the cellular modem will indicate that it also has power (described below).



Installation Guide Model GC 1010P

Step 3- Test unit functionality: When the GC1010 is connected to power a red LED next to the antenna connector will blink once, then be on solid. After about fifteen seconds it will register on the cellular network and the LED will blink slowly.

Once this happens, **wait another 30 seconds** then you can use the CelAccess phone system to open the gate/lock. Call 866-ZAP-OPEN (866-927-6736), enter the device number which can be found on the box label or device label, then enter the pound sign. Next, enter the temporary access code found on the box label. If the codes are entered correctly, you will get a verbal confirmation and an “open” command will be sent to the device. It should take less than 30 seconds for the device to receive the command.

NOTE: THE TEMPORARY ACCESS CODE WILL WORK FOR 10 TIMES INCLUDING INSTALLATION TESTING AND OWNER USE. In order to create permanent access codes, the owner must create an account as described in the Quick Start Guide.

Trouble Shooting:

LED does not turn on – If the LED does not turn on, power is not connected to the device. Be sure the leads are connected to the power supply correctly and the connector is firmly attached to the device.

LED stays solid and does not blink – The wireless unit operates on a GPRS cellular network. First, make sure the device is in coverage by checking our web site at www.celaccess.com. If you are in coverage, check the connection of the antenna. If all this is correct, the specific location might be in a poor coverage area. Contact your distributor or CelAccess at 972-231-1999 for a signal booster.

The phone system says that the code is invalid – Be sure you are entering the correct device number followed by the pound key and temporary access code then the pound key. If these are consistently rejected, it is possible the device has not been provisioned, or the temporary access code has expired. Call CelAccess customer service.

The phone system accepts the code but the lock does not open – If the system accepts the device number and access code, then the combination is valid in the CelAccess system. Note: It typically takes about a minute from the time power is connected to the device to when the device is ready to receive a command. Check to make sure the relay wires are connected properly to the control panel or lock. Use a multimeter to check continuity of the relay wires when an open command is sent. The N/O relay should close for about one half second.

IF THESE DO NOT WORK, CALL CELACCESS CUSTOMER SUPPORT.

Customer Service: 972-231-1999

E-Mail: support@celaccess.com

Customer service is available free of charge. Hours are 9:00 a.m. to 5:00 p.m. CST. If you call, please have your Model and Device ID Number to help our Technicians assist you.

CelAccess Systems, 13619 Inwood Rd, Suite 360, Dallas, TX 75244 Phone: 972-231-1999

Rev 5/6/09

Page 4 of 4